



Operating Instructions & Parts Manual

Heavy Duty Magic Lift™ Service Jacks

Model Number

25048

25058

25108

Capacity

4 Ton

5 Ton

10 Ton

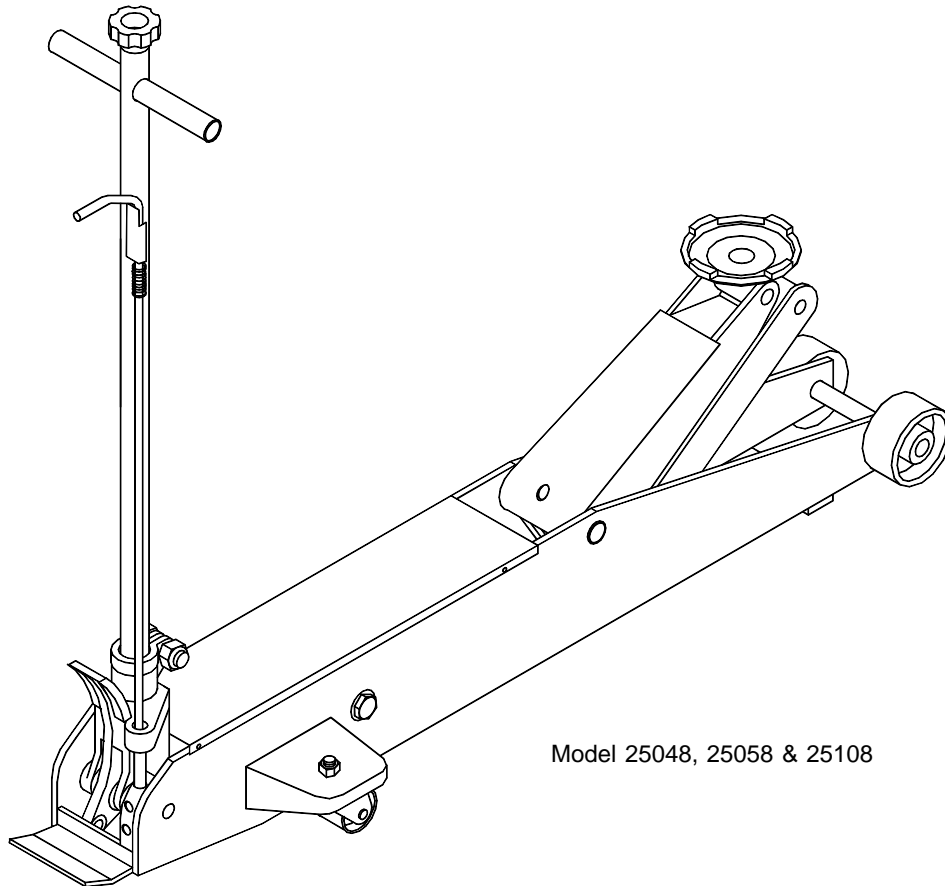

Model 25048, 25058 & 25108

Shinn Fu Co. of America, Inc. ©2002
10939 N. Pomona Avenue
Kansas City, MO 64153

OIPM#25048-SJ2
Printed in Taiwan

Save these instructions. For your safety, read, understand, and follow the information provided with and on this jack. The owner and operator of this equipment shall have an understanding of this jack and safe operating procedures before attempting to use. The owner and operator shall be aware that use and repair of this product may require special skills and knowledge. Instructions and safety information shall be conveyed in the operator's native language before use of this jack is authorized. If any doubt exists as to the safe and proper use of this jack, remove from service immediately. **Inspect before each use.** Do not use if broken, bent, cracked, or damaged parts (including labels) are noted. Any jack that appears damaged in any way, operates abnormally or is missing parts, shall be removed from service immediately. If the jack has been or suspected to have been subjected to a shock load (a load dropped suddenly, unexpectedly upon it), immediately discontinue use until jack has been checked by an Omega authorized service center. It is recommended that an annual inspection be done by qualified personnel. Labels and Operator's Manuals are available from manufacturer (see Replacement Parts, page 6).

PRODUCT DESCRIPTION

Omega Heavy Duty Magic Lift™ Service Jacks are designed to lift, **not** sustain, rated capacity loads. They are designed to be used in conjunction with jack stands. **Intended use:** To lift one wheel or axle of a vehicle for the purpose of service and/or repair of vehicle components. After lifting, loads must be immediately supported by appropriately rated jack stands. Check with vehicle owner's manual for proper lift points.

DO NOT USE TO DOLLY OR MOVE VEHICLE. DO NOT USE FOR ANY PURPOSE OTHER THAN THOSE USES OUTLINED ABOVE !

SPECIFICATIONS

| Model | Capacity | Jack Size (L X W X H) | Min. Height | Max. Height |
|-------|----------|----------------------------|-------------|-------------|
| 25048 | 4 Ton | 53 1/8" x 14 3/4" x 7 1/2" | 5" | 24" |
| 25058 | 5 Ton | 57 3/4" x 16 7/8" x 7 5/8" | 7" | 27" |
| 25108 | 10 Ton | 54 3/4" x 20" x 12 3/4" | 7" | 27" |

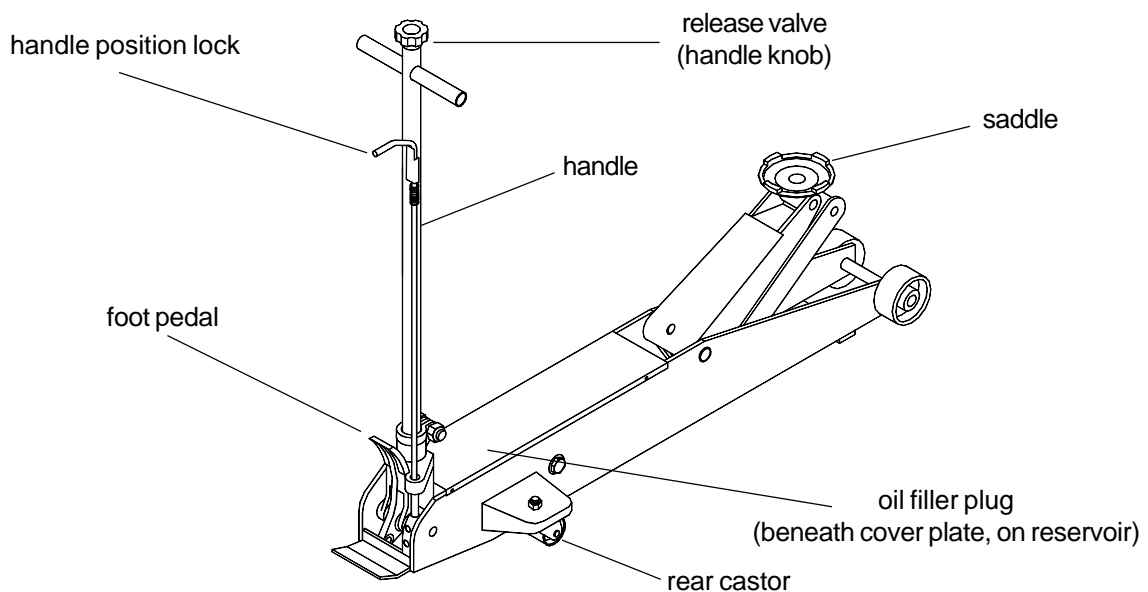

Figure 1 - Model 25048, 25058 & 25108 Nomenclature

BEFORE USE

1. Verify that the product and the application are compatible, if in doubt call Omega Technical Service (888)332-6419.
2. Before using this product, read the operator's manual completely and familiarize yourself thoroughly with the product, its components and recognize the hazards associated with its use.
3. Locate and open the release valve (counterclockwise no more than 1/2 full turn).
4. With saddle fully lowered, locate and remove the oil filler plug. Secure the handle into the handle sleeve, then pump 6 to 8 full strokes. This will help release any pressurized air which may be trapped within the reservoir. Ensure the oil level is ~3/16" above the inner cylinder as seen from the oil filler plug hole. Re-install the oil filler plug.
5. Check to ensure that jack rolls freely and that the pump operates smoothly before putting into service. Replace worn or damaged parts and assemblies with Omega Authorized Replacement Parts only. (See Replacement Parts Section). Lubricate as instructed in Maintenance Section.
6. Inspect before each use. Do not use if bent, broken or cracked components are noted.



To avoid crushing and related injuries:
NEVER work on, under or around a load supported only by a jack. ALWAYS use adequately rated jack stands.

! SAFETY MESSAGE !

Lift only on areas of the vehicle as specified by the vehicle manufacturer. Do not use adapters or accessories that are not provided initially.

⚠ WARNING

Study, understand, and follow all instructions provided with and on this device. Do not exceed rated capacity. This is a lifting device only. After lifting, immediately transfer the load to appropriately rated vehicle stands. Never work on, under, or around a load supported by this device. Use only on hard, level surfaces capable of sustaining rated capacity loads. Do not move or dolly loads with this device. Do not modify this device. Failure to heed these markings may result in personal injury and/or property damage.

ASSEMBLY

Little, if any, assembly is required of these jacks. Always secure the handle into the handle fork by means of the bolt and lock washer provided. Tighten securely to prevent accidental removal of handle while in use. Familiarize yourself with the illustrations in the operator's manual. Know your jack and how it operates before attempting to use.

OPERATION

Lifting

1. Place vehicle in park, with emergency brake on and wheels securely chocked to prevent inadvertent vehicle movement.
2. Locate and close release valve by turning handle knob clockwise, firmly. Center jack saddle under lift point.
3. Verify lift point, then pump handle to contact lift point. To lift, pump handle until load reaches desired height.
4. Transfer the load immediately to appropriately rated jack stands.

Lowering

1. Raise load high enough to clear the jack stands, then carefully remove jack stands (**always** used in pairs).
2. Slowly turn the handle knob counterclockwise, but no more than 1/2 turn. If the load fails to lower:
 - a. Use another jack to raise the vehicle high enough to reinstall jack stands.
 - b. Remove the affected jack and then the stands.
 - c. Using the other jack, lower the load by turning the handle knob counterclockwise, but no more than 1/2 turn.
3. After removing jack from under the load, push saddle down to reduce ram exposure to rust and contamination.

MAINTENANCE

Important: Use only a good grade hydraulic jack oil. Avoid mixing different types of fluid and **Never** use brake fluid, turbine oil, transmission fluid, motor oil or glycerin. Improper fluid can cause failure of the jack and the potential for sudden and immediate loss of load. We recommend Mobil DTE 13.

Adding oil

1. With saddle fully lowered set jack in its upright, level position. Locate and remove oil filler plug.
2. Fill with oil until ~3/16" above the inner cylinder as seen from the oil filler plug hole. Reinstall the oil filler plug.

Changing oil

For best performance and longest life, replace the complete fluid supply at least once per year.

1. With saddle fully lowered, remove the oil filler plug.
2. Lay the jack on its side and drain the fluid into a suitable container.

Note: Dispose of hydraulic fluid in accordance with local regulations.

3. Fill with oil until ~3/16" above the inner cylinder as seen from the oil filler plug hole. Reinstall the oil filler plug.

MAINTENANCE (continued)

Lubrication

Pneumatic) When used on a daily basis, air actuated units should be internally lubricated before each use. Use **ONLY** good quality air tool lubricant. If no in-line, air line oiler is used, pour a teaspoon of air tool oil into the inlet of the air control valve. Simply operate the jack using the air feature in order to fully distribute the oil.

A periodic coating of light lubricating oil to pivot points, axles and hinges will help to prevent rust and assure that wheels, casters and pump assemblies move freely.

Cleaning

Periodically check the pump piston and ram for signs of rust or corrosion. Clean as needed and wipe with an oily cloth.

Note: Never use sandpaper or abrasive material on these surfaces !

Storage

When not in use, store the jack with saddle fully lowered.

TROUBLESHOOTING

| Symptom | Possible Causes | Corrective Action |
|-------------------------------------|----------------------------------------------------------------------------------------------------------------------------------------------------------|----------------------------------------------------------------------------------------------------------------------------------------------------------------------------------------------------|
| Jack will not lift load | <ul style="list-style-type: none"> • Release valve not tightly closed • Overload condition | <ul style="list-style-type: none"> • Ensure release valve tightly closed • Remedy overload condition |
| Jack bleeds off after lift | <ul style="list-style-type: none"> • Release valve not tightly closed • Overload condition • Hydraulic unit malfunction | <ul style="list-style-type: none"> • Ensure release valve tightly closed • Remedy overload condition • Contact Omega Tech. Service |
| Jack will not lower after unloading | <ul style="list-style-type: none"> • Reservoir overfilled • Linkages binding | <ul style="list-style-type: none"> • Drain fluid to proper level • Clean and lubricate moving parts |
| Poor lift performance | <ul style="list-style-type: none"> • Fluid level low • Air trapped in system | <ul style="list-style-type: none"> • Ensure proper fluid level • With ram fully retracted, remove oil filler plug to let pressurized air escape, reinstall oil filler plug |
| Will not lift to full extension | <ul style="list-style-type: none"> • Fluid level low | <ul style="list-style-type: none"> • Ensure proper fluid level |

ONE YEAR LIMITED WARRANTY

For a period of one (1) year from date of purchase, **Shinn Fu Co. of America, Inc.** will repair or replace, at its option, without charge, any of its products which fails due to a defect in material or workmanship, or which fails to conform to any implied warranty not excluded hereby.

Performance of any obligation under this warranty may be obtained by returning the warranted product, freight prepaid, to **Shinn Fu Co. of America, Inc.** Warranty Service Department, 10939 N. Pomona Ave., Kansas City, MO 64153.

Except where such limitations and exclusions are specifically prohibited by applicable law, (1) the CONSUMER'S SOLE AND EXCLUSIVE REMEDY SHALL BE THE REPAIR OR REPLACEMENT OF DEFECTIVE PRODUCTS AS DESCRIBED ABOVE, and (2) **Shinn Fu Co. of America, Inc.** SHALL NOT BE LIABLE FOR ANY CONSEQUENTIAL OR INCIDENTAL DAMAGE OR LOSS WHATSOEVER, and (3) THE DURATION OF ANY AND ALL EXPRESSED AND IMPLIED WARRANTIES, INCLUDING WITHOUT LIMITATION, ANY WARRANTIES OF MERCHANTABILITY AND FITNESS FOR A PARTICULAR PURPOSE, IS LIMITED TO A PERIOD OF ONE (1) YEAR FROM DATE OF PURCHASE.

Some states do not allow limitations on how long an implied warranty lasts, so the above limitation may not apply to you. Some states do not allow the exclusion or limitation of incidental or consequential damages, so the above limitation or exclusion may not apply to you. This warranty gives you specific legal rights, and you may also have other rights which vary from state to state.

REPLACEMENT PARTS

Available Parts: Please refer to the Parts drawing on page 6 when ordering parts. Not all components of the jack are replacement items, but are illustrated as a convenient reference of location and position in the assembly sequence. When ordering parts, give Model number, serial number and description. Call or write for current pricing: Shinn Fu Company of America, Inc. 10939 N. Pomona Ave. Kansas City, MO 64153, U.S.A. Tel:(888)332-6419 Fax:(816)891-6599 E-Mail: sales@omegalift.com Omega Website: <http://www.omegalift.com>

Models 25048, 25058 & 25108

| <u>Parts No.</u> | <u>Description</u> | <u>Quantity</u> |
|------------------|---------------------------|-----------------|
| 1 | power unit | 1 |
| 2 | oil filler plug | 1 |
| 3 | saddle | 1 |
| 4 | front wheel assembly | 2 |
| 5 | rear castor assembly | 2 |
| 6 | handle assembly | 1 |
| 7 | return spring (I) | 1 |
| 8 | return spring (II) | 1 |
| 9 | foot pedal | 1 |
| 10 | bolt, washer & nut | 1 |
| - | label(s) (not shown) | 1 |
| - | manual (OIPM # 25048-SJ2) | 1 |

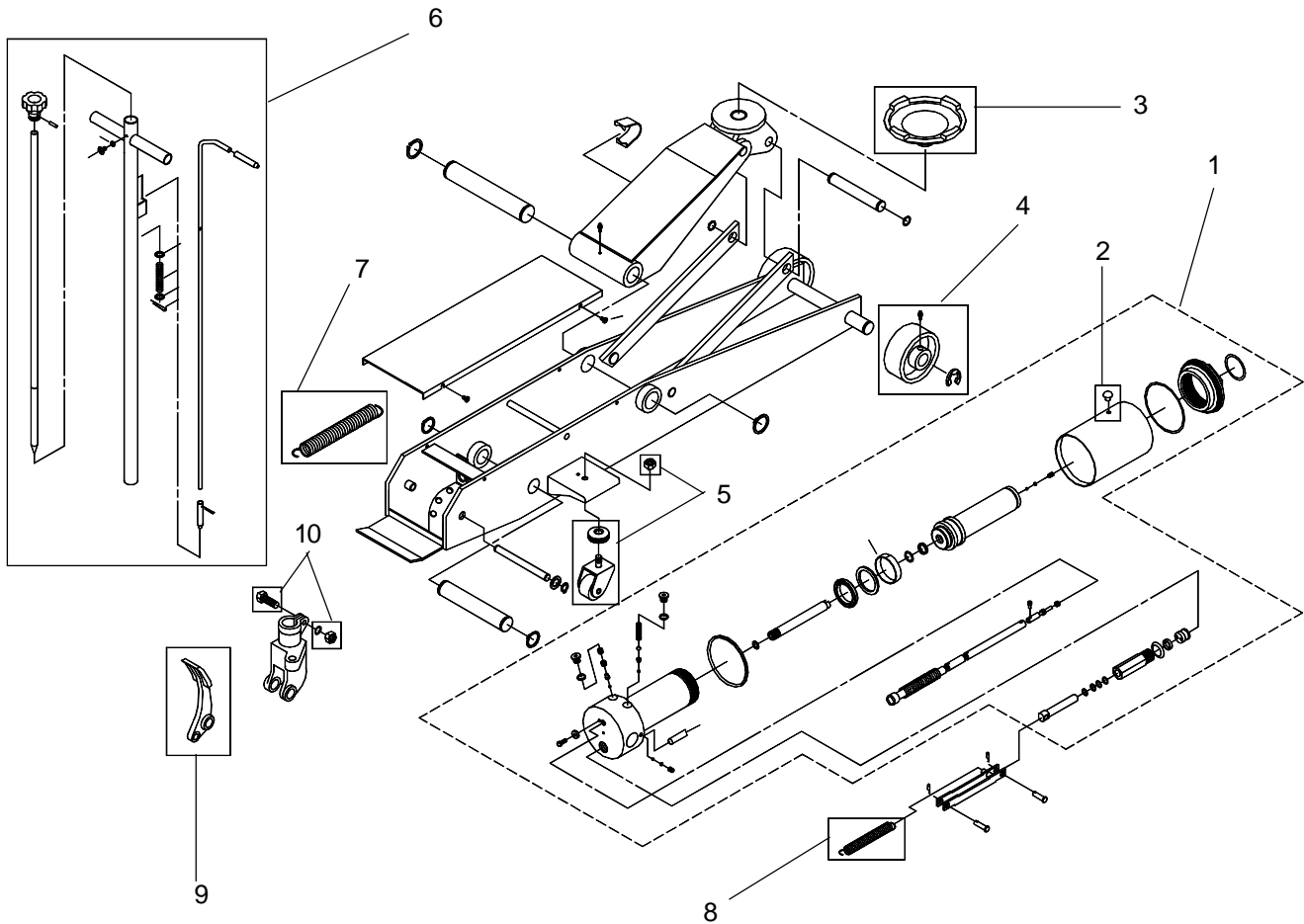

Figure 2 - Replacement Parts Illustration for Model 25048, 25058 & 25108

