



Operating Instructions & Parts Manual

Magic Lift™ Hydraulic Service Jack w/Swivel Handle Fork

**Model Number
26025**

**Capacity
2 1/2 Ton**

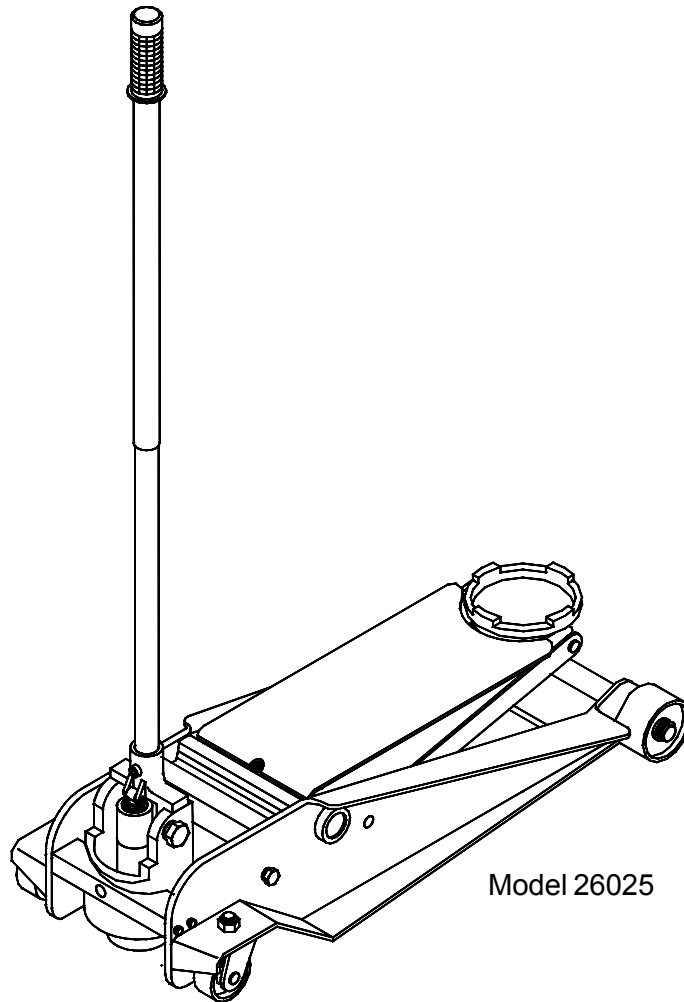

Model 26025

U.S. Patent No. 5,755,099 & 5,946,912 & 6,505,816 B1
U.S. Patent No. Des. 421,516

**SFA Companies © 2003
10939 N. Pomona Avenue
Kansas City, MO 64153**

OIPM # 26025-SJ3
Printed in China

Save these instructions. For your safety, read, understand, and follow the information provided with and on this jack. The owner and operator of this equipment shall have an understanding of this jack and safe operating procedures before attempting to use. The owner and operator shall be aware that use and repair of this product may require special skills and knowledge. Instructions and safety information shall be conveyed in the operator's native language before use of this jack is authorized. If any doubt exists as to the safe and proper use of this jack, remove from service immediately. **Inspect before each use.** Do not use if broken, bent, cracked, or damaged parts (including labels) are noted. Any jack that appears damaged in any way, operates abnormally or is missing parts, shall be removed from service immediately. If the jack has been or suspected to have been subjected to a shock load (a load dropped suddenly, unexpectedly upon it), immediately discontinue use until jack has been checked by an Omega authorized service center. It is recommended that an annual inspection be done by qualified personnel. Labels and Operator's Manuals are available from manufacturer (see Replacement Parts, page 6).

PRODUCT DESCRIPTION

This Magic Lift™ Hydraulic Service Jack w/Swivel Handle Fork is designed to lift, but not sustain, rated capacity loads. This model is designed to be used in conjunction with jack stands. **Intended use:** To lift one axle of a vehicle for the purpose of service and/or repair of vehicle components. After lifting, loads must be immediately supported by appropriately rated jack stands. Check with vehicle owner's manual for proper lift points.

DO NOT USE AS A WHEEL DOLLY !

SPECIFICATIONS

Model	Capacity	Jack Size (L X W X H)	Min. Height	Max. Height
26025	2 1/2 Ton	31" X 13 1/4" X 6 1/4"	4"	20"

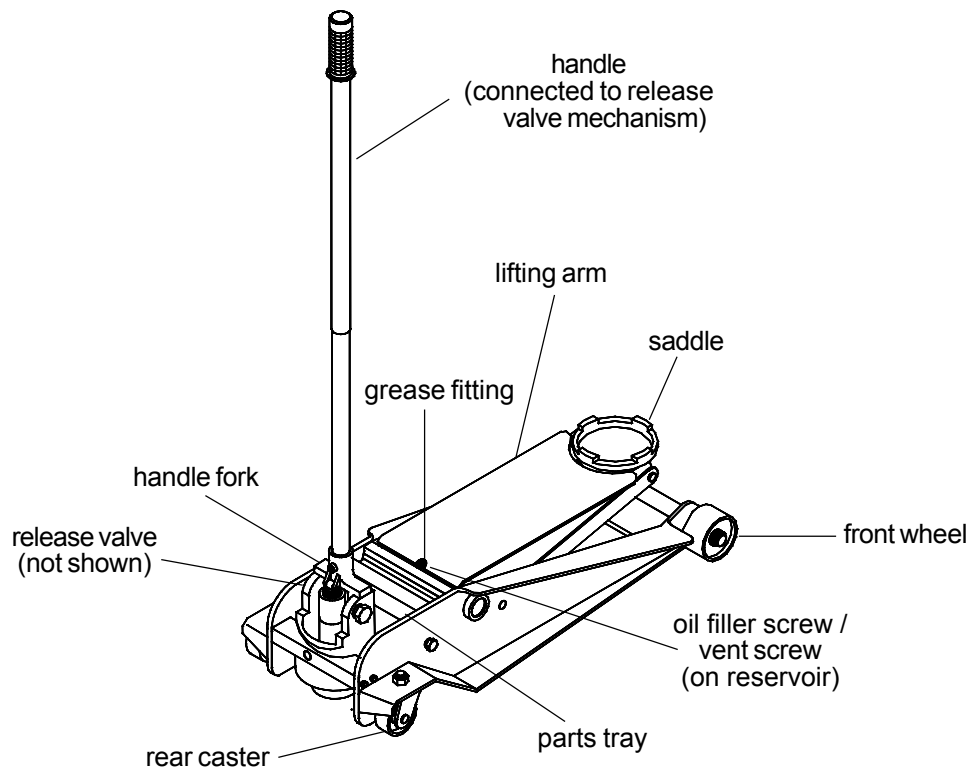

Figure 1 - Model 26025 Nomenclature

ASSEMBLY

Little, if any, assembly is required of this jack. Always secure the handle into the handle fork by means of the bolt and lock washer provided. Tighten securely to prevent accidental removal of handle while in use. Familiarize yourself with the illustrations in this operator's manual. Know your jack and how it operates before attempting to use.

Note: Lift only on areas of the vehicle as specified by the vehicle manufacturer. Do not use adapters or accessories that are not provided initially.

BEFORE USE

1. Verify that the product and the application are compatible, if in doubt call Omega Technical Service (888) 332-6419.
2. Before using this product, read the operator's manual completely and familiarize yourself thoroughly with the product, its components and recognize the hazards associated with its improper use.
3. Open the release valve by turning the handle counterclockwise no more than 1/2 full turn.
4. With saddle fully lowered, locate and remove the oil filler screw / vent screw. Insert the handle into the handle sleeve, then pump 6 to 8 full strokes. This will help release any pressurized air which may be trapped within the reservoir. Ensure the oil level is ~3/16" above the inner cylinder as seen from the oil filler screw / vent screw hole. Reinstall the oil filler screw / vent screw.
5. Check to ensure that jack rolls freely and that the pump operates smoothly before putting into service. Replace worn or damaged parts and assemblies with Omega Replacement Parts only. (See Replacement Parts Section). Lubricate as instructed in Maintenance Section.

OPERATION

Lifting

1. Place vehicle in park, with emergency brake on and wheels securely chocked to prevent inadvertent vehicle movement.
2. Locate and close release valve by turning handle clockwise, firmly. Center jack saddle under lift point.
3. Verify lift point, then use handle pump to contact lift point. To lift, pump handle until load reaches desired height.
4. Transfer the load immediately to appropriately rated jack stands.

⚠ WARNING

Study, understand, and follow all instructions provided with and on this device before use. Do not exceed rated capacity. This is a lifting device only. After lifting, immediately transfer the load to appropriately rated vehicle stands. Never work on, under, or around a load supported by this device. Use only on hard, level surfaces capable of sustaining rated capacity loads. Do not move or dolly loads with this device. Do not modify this device. Failure to heed these markings may result in personal injury and/or property damage.

OPERATION (continued)

Lowering

1. Raise load high enough to clear the jack stands, then carefully remove jack stands (**always** used in pairs).
2. Slowly turn the handle counterclockwise, but no more than 1/2 turn. If the load fails to lower:
 - a. Use another jack to raise the vehicle high enough to reinstall jack stands.
 - b. Remove the affected jack and then the stands.
 - c. Using the other jack, lower the load by turning the operating handle counterclockwise, but no more than 1/2 turn.
3. After removing jack from under the load, push saddle down to reduce ram exposure to rust and contamination.

⚠ WARNING

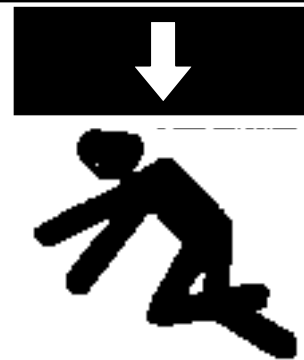

To avoid crushing and related injuries: NEVER work on, under or around a load supported only by a jack. ALWAYS use adequately rated jack stands.

MAINTENANCE

Important: Use only a good grade hydraulic jack oil. Avoid mixing different types of fluid and NEVER use brake fluid, turbine oil, transmission fluid, motor oil or glycerin. Improper fluid can cause failure of the jack and the potential for sudden and immediate loss of load. We recommend Mobil DTE 13M or equivalent.

Adding oil

1. With saddle fully lowered set jack in its upright, level position. Locate and remove oil filler screw / vent screw.
2. Fill with oil until ~3/16" above the inner cylinder as seen from the oil filler screw / vent screw hole. Reinstall the oil filler screw / vent screw.

Changing oil

For best performance and longest life, replace the complete fluid supply at least once per year.

1. With saddle fully lowered, remove the oil filler screw / vent screw.
2. Lay the jack on its side and drain the fluid into a suitable container.

MAINTENANCE (continued)

Note: Dispose of hydraulic fluid in accordance with local regulations.

3. Fill with oil until ~3/16" above the inner cylinder as seen from the oil filler screw / vent screw hole. Reinstall the oil filler screw / vent screw.

Lubrication

A periodic coating of light lubricating oil to pivot points, axles and hinges will help to prevent rust and assure that wheels, casters and pump assemblies move freely.

Cleaning

Periodically check the pump piston and ram for signs of rust or corrosion. Clean as needed and wipe with an oily cloth.

Note: Never use sandpaper or abrasive material on these surfaces !

Storage

When not in use, store the jack with saddle fully lowered.

TROUBLESHOOTING

Symptom	Possible Causes	Corrective Action
Jack will not lift load	<ul style="list-style-type: none"> • Release valve not tightly closed • Overload condition 	<ul style="list-style-type: none"> • Ensure release valve tightly closed • Remedy overload condition
Jack *bleeds off after lift	<ul style="list-style-type: none"> • Release valve not tightly closed • Overload condition • Hydraulic unit malfunction 	<ul style="list-style-type: none"> • Ensure release valve tightly closed • Remedy overload condition • Replace hydraulic unit
Jack will not lower after unloading	<ul style="list-style-type: none"> • Reservoir overfilled • Linkages binding 	<ul style="list-style-type: none"> • Drain fluid to proper level • Clean and lubricate moving parts
Poor lift performance	<ul style="list-style-type: none"> • Fluid level low • Air trapped in system 	<ul style="list-style-type: none"> • Ensure proper fluid level • With ram fully retracted, remove oil filler screw / vent screw to let pressurized air escape, then reinstall oil filler screw / vent screw
Will not lift to full extension	<ul style="list-style-type: none"> • Fluid level low 	<ul style="list-style-type: none"> • Ensure proper fluid level

* "bleeds off" means to lose pressure

ONE YEAR LIMITED WARRANTY

For a period of one (1) year from date of purchase, **SFA Companies** will repair or replace, at its option, without charge, any of its products which fails due to a defect in material or workmanship, or which fails to conform to any implied warranty not excluded hereby.

Performance of any obligation under this warranty may be obtained by returning the warranted product, freight prepaid, to **SFA Companies** Warranty Service Department, 10939 N. Pomona Ave., Kansas City, MO 64153.

Except where such limitations and exclusions are specifically prohibited by applicable law, (1) the CONSUMER'S SOLE AND EXCLUSIVE REMEDY SHALL BE THE REPAIR OR REPLACEMENT OF DEFECTIVE PRODUCTS AS DESCRIBED ABOVE, and (2) **SFA Companies** SHALL NOT BE LIABLE FOR ANY CONSEQUENTIAL OR INCIDENTAL DAMAGE OR LOSS WHATSOEVER, and (3) THE DURATION OF ANY AND ALL EXPRESSED AND IMPLIED WARRANTIES, INCLUDING WITHOUT LIMITATION, ANY WARRANTIES OF MERCHANTABILITY AND FITNESS FOR A PARTICULAR PURPOSE, IS LIMITED TO A PERIOD OF ONE (1) YEAR FROM DATE OF PURCHASE.

Some states do not allow limitations on how long an implied warranty lasts, so the above limitation may not apply to you. Some states do not allow the exclusion or limitation of incidental or consequential damages, so the above limitation or exclusion may not apply to you. This warranty gives you specific legal rights, and you may also have other rights which vary from state to state.

REPLACEMENT PARTS

Available Parts: Please refer to the Parts drawing when ordering parts. Not all components of the jack are replacement items, but are illustrated as a convenient reference of location and position in the assembly sequence. When ordering parts, give Model number, serial number and description on this page. Call or write for current pricing: SFA Companies, 10939 N. Pomona Ave. Kansas City, MO 64153, U.S.A. Tel:(888)332-6419 Fax:(816)891-6599 E-Mail: sales@omegalift.com Omega Website: http://www.omegalift.com

Model # 26025

Part. No.	Description	Quantity
1	power unit	1
2	front wheel assembly	2
3	rear caster assembly	2
4	saddle	1
5	oil filler screw / vent screw assembly	1
6	release valve cable	1
7	handle assembly	1
8	handle grip	1
9	bolt & washer	1
10	handle fork return spring	2
11	return spring	2
-	label (not shown)	1
-	manual (OIPM# 26025-SJ3)	1

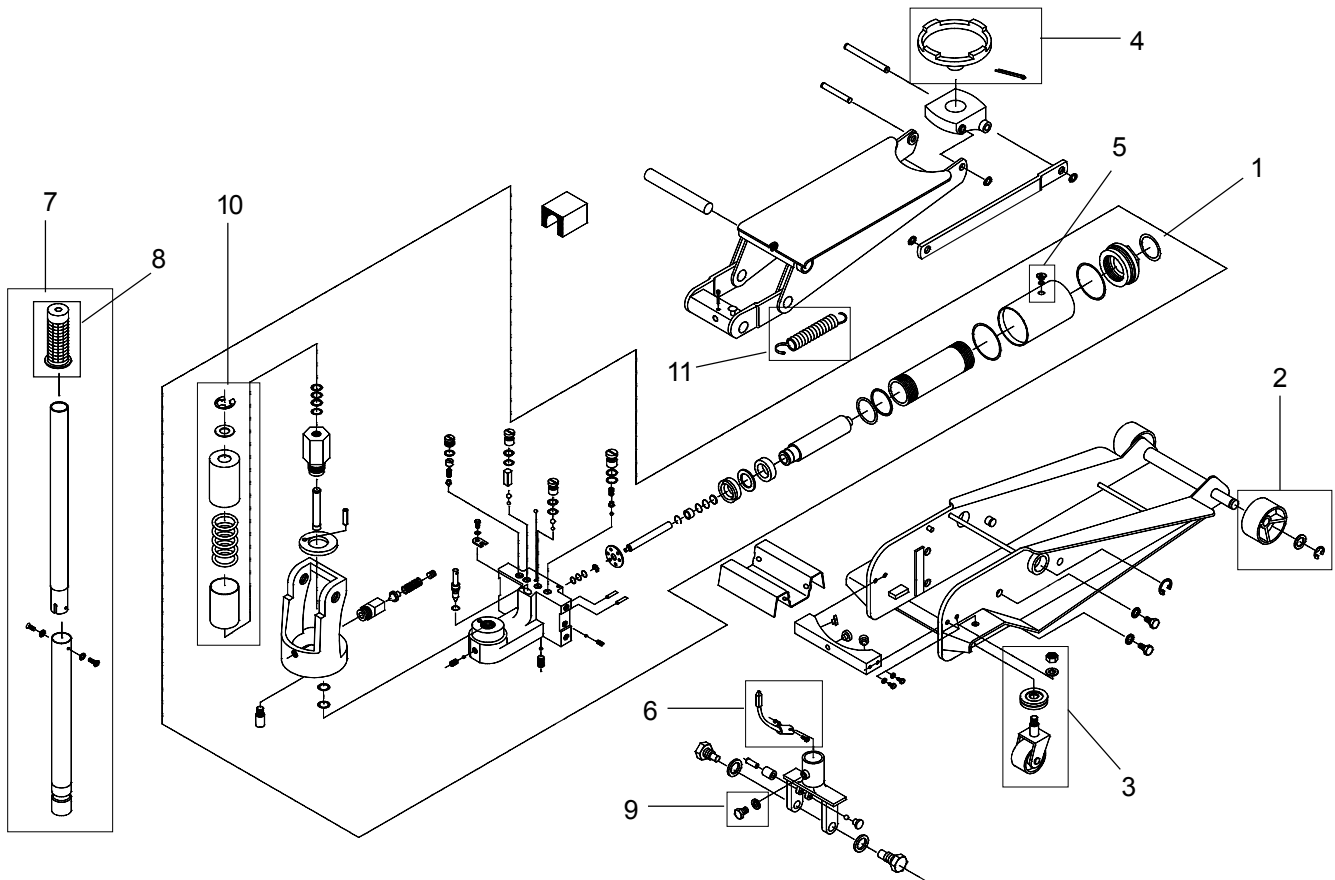

Figure 2 - Replacement Parts Illustration for Model 26025

